

DUPLEX UNIT (G694)

1. SPECIFICATIONS

Copy Paper Size :	Width Max. 297 mm, Min. 182 mm Length Max. 432 mm, Min. 148 mm
Paper Weight :	60 g to 90 g
Capacity:	1 sheet
Power Source :	24 Vdc from the copier
Power Consumption :	25 W
Dimensions (W x D x H) :	Duplex Tray - 530 x 565 x 255 mm Inverter Unit - 75 x 428 x 101 mm
Weight :	Duplex Tray - 4.1 kg Inverter Unit - 1 kg

2. COMPONENT LAYOUT

2.1 MECHANICAL COMPONENT LAYOUT

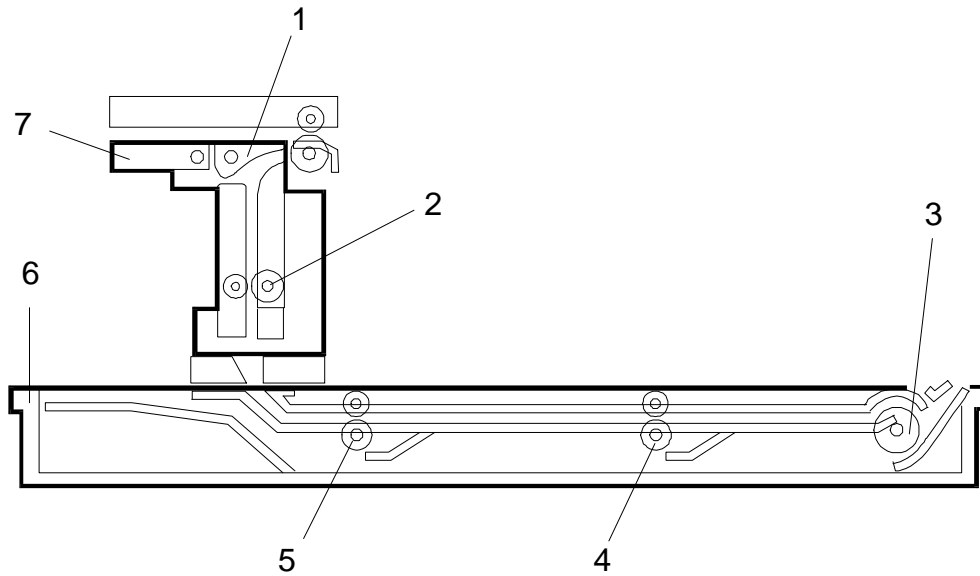

G694O006.wmf

- | | |
|-----------------------------------|--------------------------|
| 1. Duplex Junction Gate | 5. Left Transport Roller |
| 2. Inverter Unit Transport Roller | 6. Duplex Tray |
| 3. Duplex Feed Roller | 7. Inverter Unit |
| 4. Central Transport Roller | |

2.2 ELECTRICAL COMPONENT LAYOUT

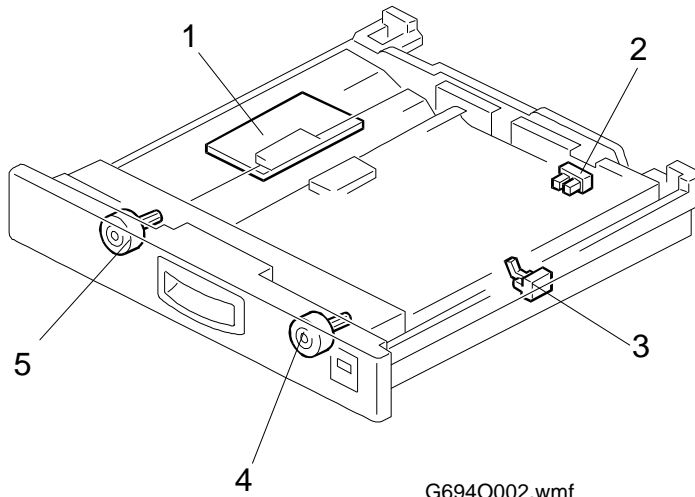

G694O002.wmf

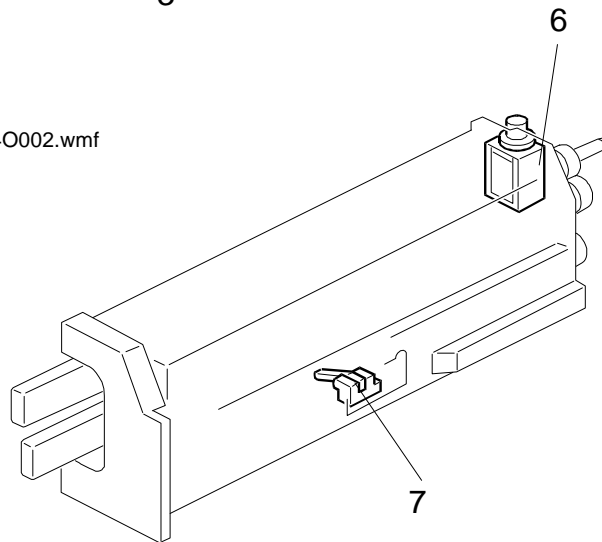

G694O003.wmf

- 1. Duplex Control Board
- 2. Duplex Turn Sensor
- 3. Duplex Exit Sensor
- 4. Duplex Feed Motor

- 5. Duplex Transport Motor
- 6. Duplex Junction Gate Solenoid
- 7. Duplex Entrance Sensor

2.3 ELECTRICAL COMPONENT DESCRIPTION

Symbol	Name	Function	Index No.
Motors			
M1	Duplex Transport	Drives the left and central transport rollers.	5
M2	Duplex Feed	Drives the duplex feed roller.	4
Sensors			
S1	Duplex Entrance	Detects misfeeds and controls the transport motor speed.	7
S2	Duplex Turn	Detects misfeeds, controls the paper stop position, and controls the duplex feed roller timing.	2
S3	Duplex Exit	Detects misfeeds and controls the duplex feed roller off timing.	3
Solenoid			
SOL1	Duplex Junction Gate Control	Controls the duplex junction gate.	6
PCBs			
PCB1	Duplex Control	Controls the overall duplex tray operation.	1

3. DRIVE LAYOUT

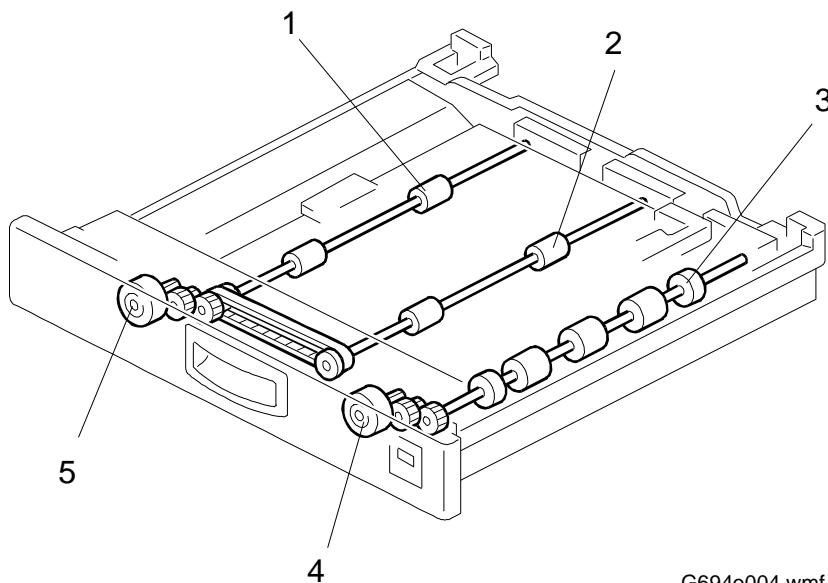

G694o004.wmf

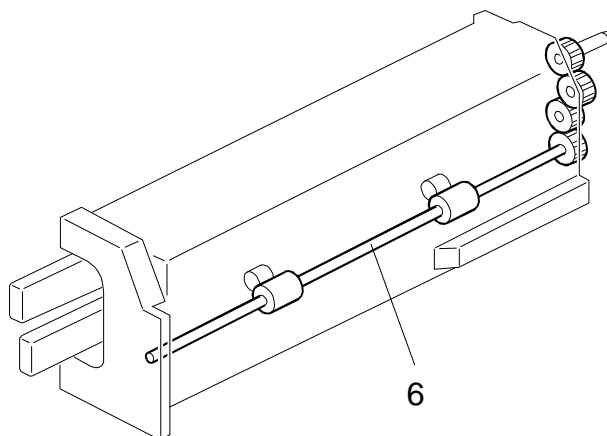

G694O005.wmf

- 1. Left Transport Roller
- 2. Central Transport Roller
- 3. Duplex Feed Roller

- 4. Duplex Feed Motor
- 5. Transport Motor
- 6. Inverter Unit Transport Roller

Options

4. BASIC OPERATION

4.1 A3 PAPER SIZE

1. When the leading edge of the paper [A] has passed through the fusing unit, the junction gate solenoid energizes and the junction gate [B] is opened. The paper is guided to the inverter unit [C]. The on timing of the junction gate solenoid is controlled by the registration sensor.

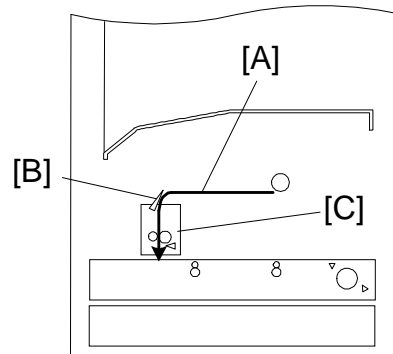

G694O506.wmf

2. The paper is fed to the duplex tray [D] by the inverter unit transport roller [E], and to the duplex feed roller [F] by the left and central transport rollers ([G], [H]) in the duplex tray. When the trailing edge of the paper has passed through the duplex entrance sensor [I], the speed of the paper doubles.

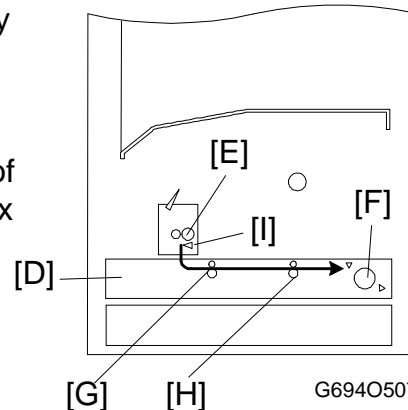

G694O507.wmf

3. The paper is inverted by the duplex feed roller [F]. The duplex feed motor turns off shortly after the trailing edge of the paper passes through the duplex turn sensor [J].

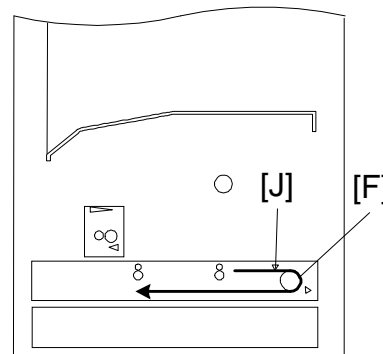

G694O508.wmf

4. Almost immediately after stopping, the duplex feed motor turns on again in reverse, and the inverted paper is fed back to the copier. When the trailing edge of the paper passes through the duplex exit sensor [K], the duplex feed motor turns off.

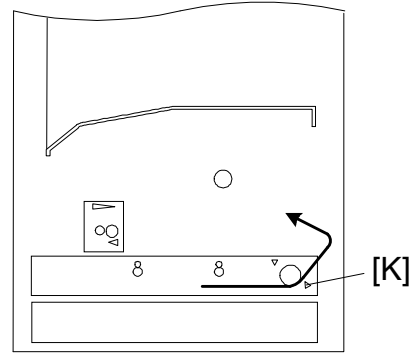

G694O509.wmf

5. The paper is transported to the exit area.

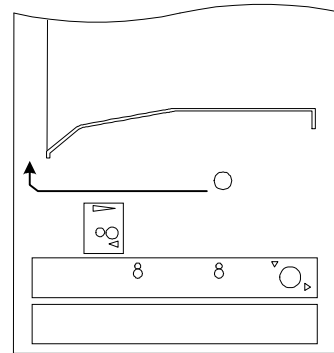

G694O521.wmf

4.2 SHORTER THAN A4 LENGTHWISE (MEMORY COPY)

8 Original (ã ~ °)

1. Two sheets of paper [A] [B] are fed from the lower paper tray and the first paper transported to the duplex tray in the same way as for A3.

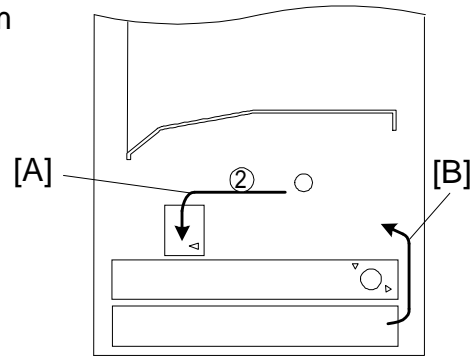

G694O510.wmf

2. The first sheet [A] of paper is reversed by the duplex turn roller and the second sheet [B] is transported to the duplex unit in the same way as for A3 size.

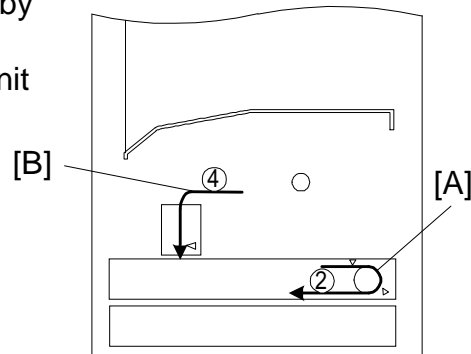

G694O511.wmf

3. The first sheet [A] is fed out to the copier from the duplex tray in the same way as for A3 size. The transport motor stops when the leading edge of the second sheet [B] turns on the duplex turn sensor [C]. The second sheet [B] stops in the waiting position.

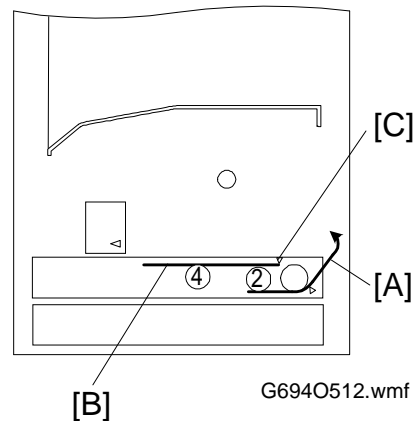

G694O512.wmf

4. The second sheet [B] starts again when the trailing edge of the first sheet [A] passes through the duplex exit sensor [D], and it is reversed. The second sheet is being reversed, the third sheet [E] is fed out from the lower tray after the first sheet has reached the registration roller.

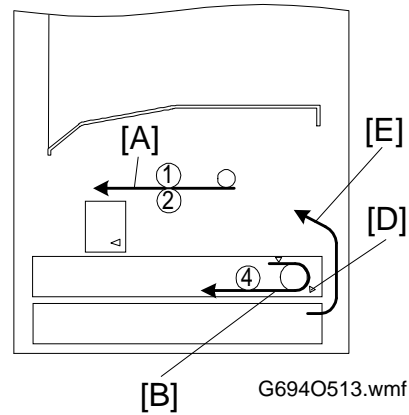

5. The first sheet [A] is fed out to the copy tray. The second sheet [B] is fed out from the duplex tray. The third sheet [E] is transported to the duplex tray.

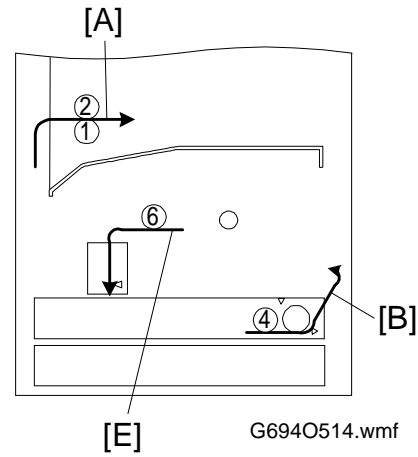

6. The second sheet [B] is transported to the exit section. The third sheet [E] is reversed. While the third sheet is being reversed, the fourth sheet [F] is fed out from the lower tray after the second sheet [B] has reached the registration roller.

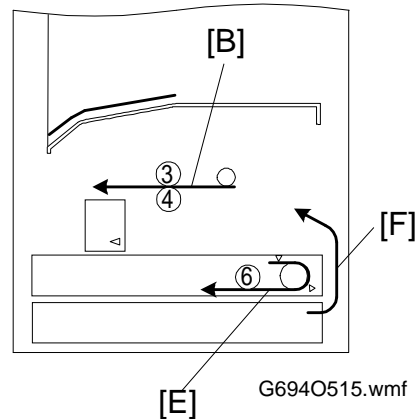

Options

7. The second sheet [B] is fed out to the copy tray. The third sheet [E] is fed out from the duplex tray. The fourth sheet [F] is transported to the duplex tray.

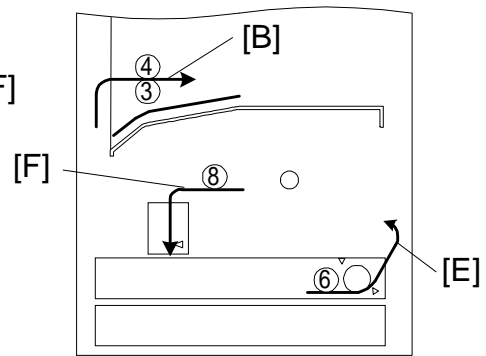

G694O516.wmf

8. The third sheet [E] is transported to the exit section. The fourth sheet [F] is reversed.

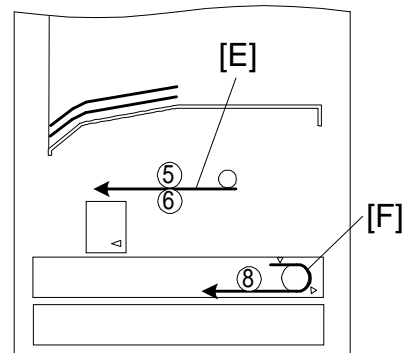

G694O517.wmf

9. The third sheet [E] is fed out to the copier exit tray. The fourth sheet [F] is fed out from the duplex tray.

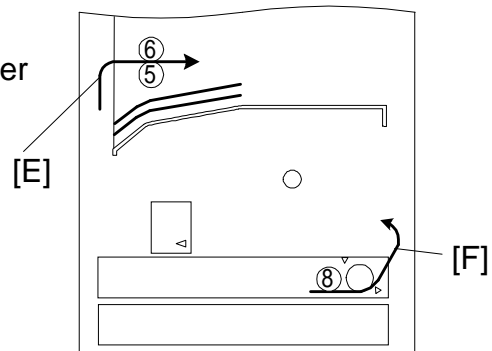

G694O518.wmf

10. The fourth sheet [F] is transported to the exit section.

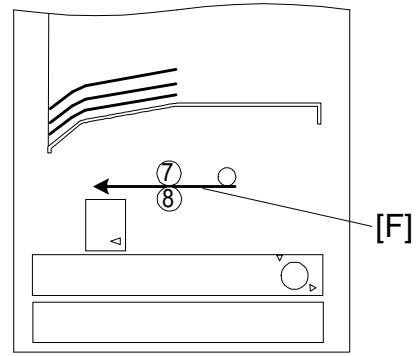

G694O519.wmf

11. The fourth sheet [F] is fed out to the copier exit tray.

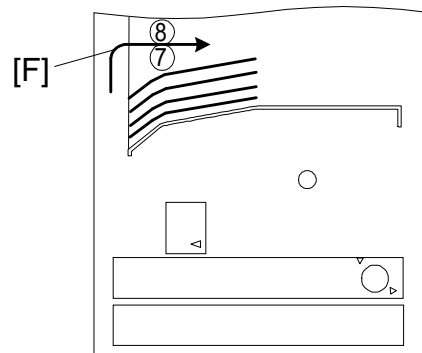

G694O520.wmf

Options

5. DETAILED DESCRIPTIONS

5.1 DUPLEX JUNCTION GATE MECHANISM

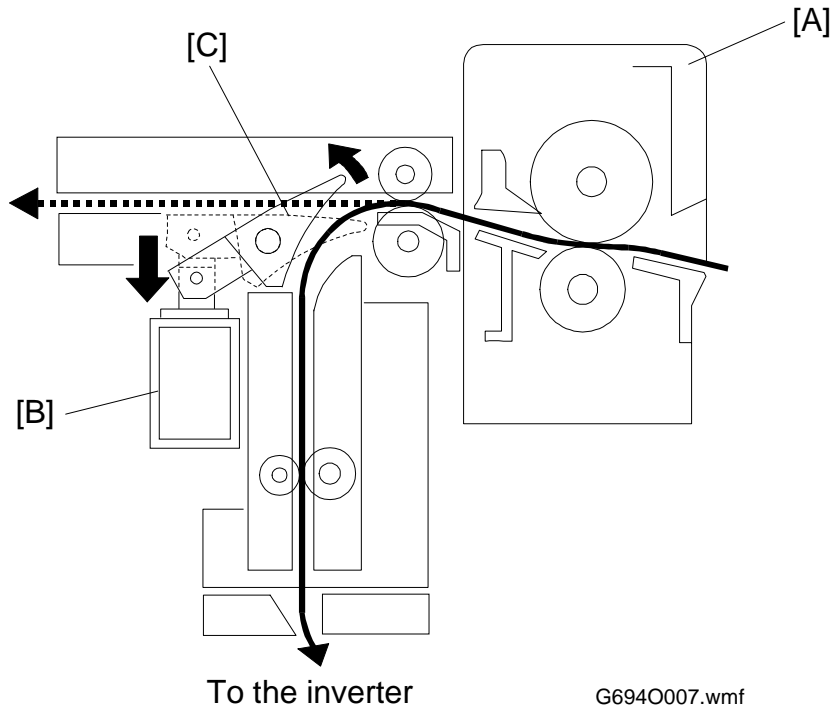

The paper that is fed out from the fusing unit [A] is delivered to the copier exit section or to the inverter unit.

When the duplex junction gate solenoid [B] energizes, the junction gate [C] opens, and the paper is fed to the inverter unit.

5.2 PAPER TRANSPORT AND FEED MECHANISM

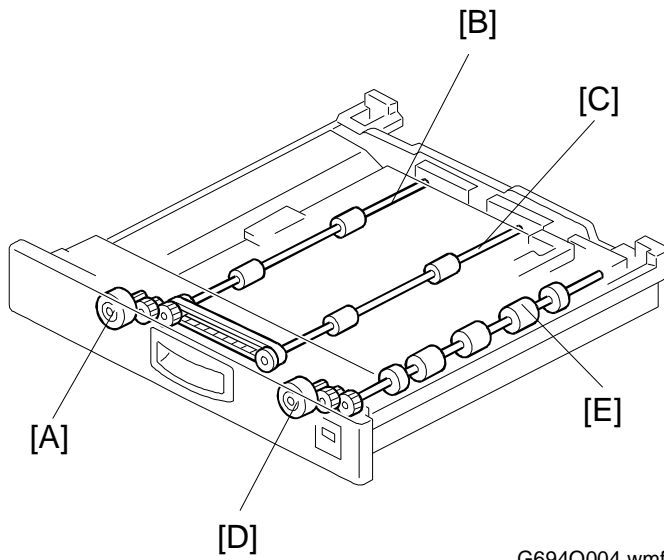

G694O004.wmf

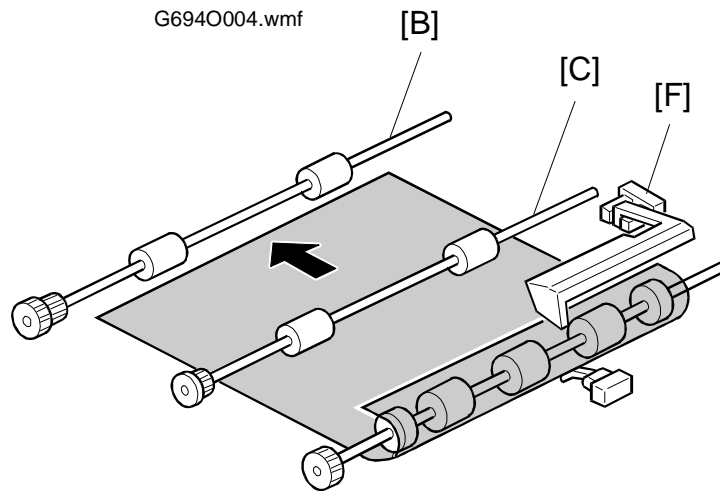

G694O008.wmf

The duplex transport motor [A] drives the left and central transport rollers ([B], [C]) and the duplex feed motor [D] drives the duplex feed roller [E].

The paper sent from the inverter unit is fed by the left and central transport rollers to the duplex feed roller.

The duplex feed roller inverts the paper. The duplex feed roller stops shortly after the trailing edge of the paper turns off the duplex turn sensor [F]. Immediately after this, the duplex feed roller [E] turns in reverse and the inverted paper is fed out to the copier.

Options

5.3 TIMING CHARTS

5.3.1 A3 (without memory)

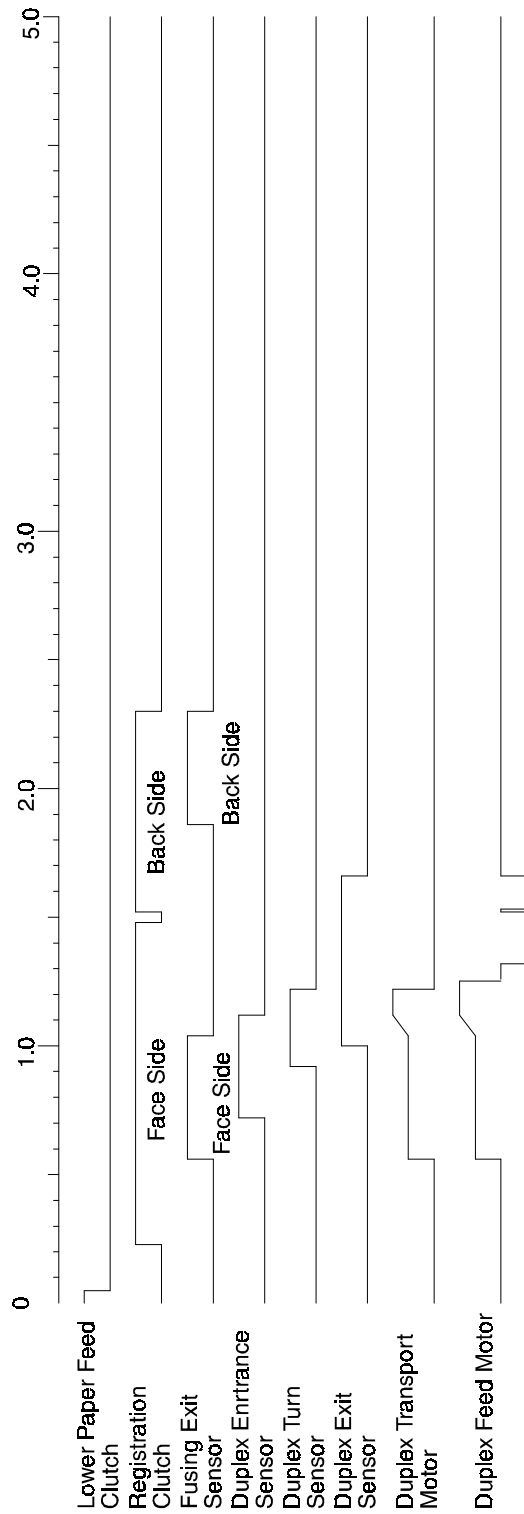

5.3.2 A4 sideways (Memory)

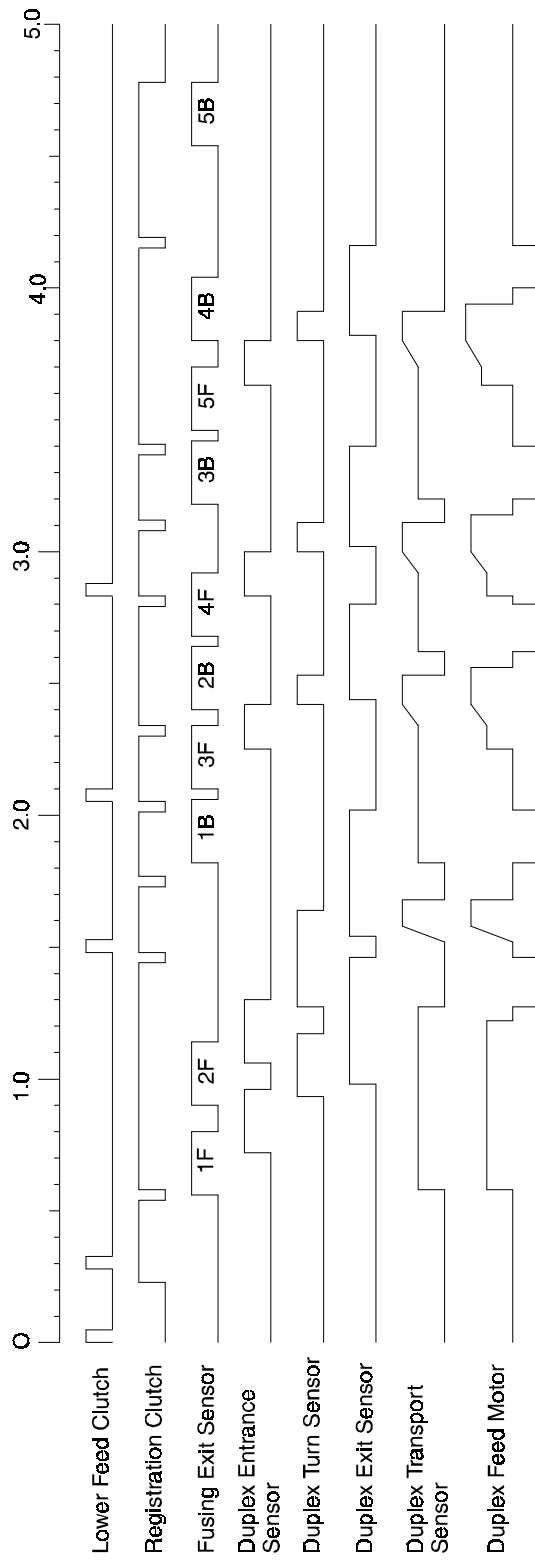

Options

5.4 OVERALL ELECTRICAL CIRCUIT

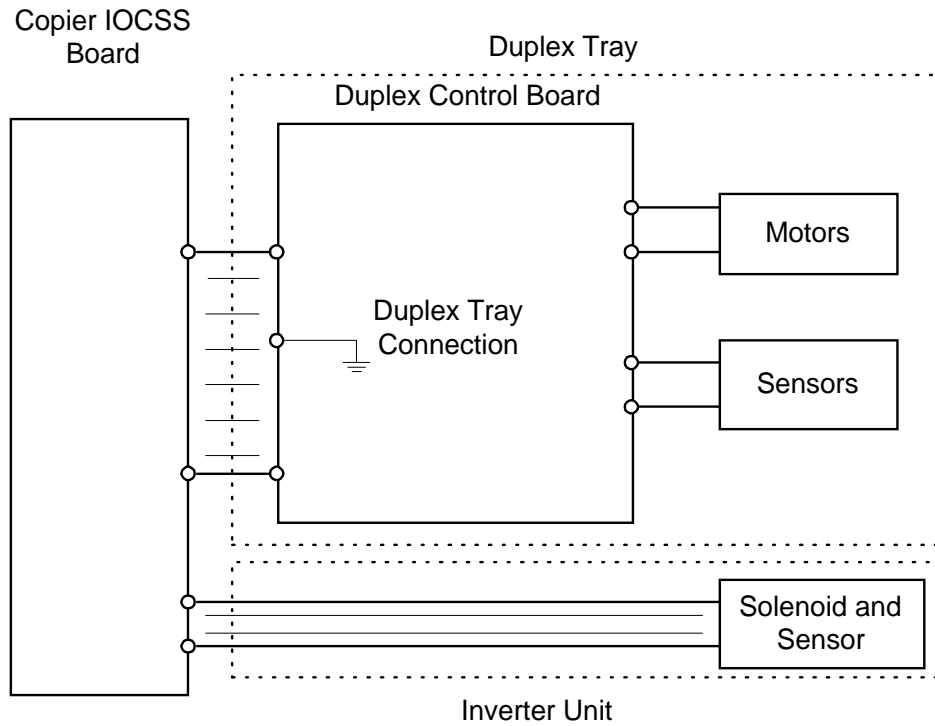

A694O502.wmf

The solenoid and sensor in the inverter unit are directly connected to the copier. The motors and sensors in the duplex tray are controlled by the duplex control board.

When the duplex tray connector is connected (this happens when the duplex tray is slid into the machine), the duplex tray connection signal to the copier is grounded. Then the copier detects that the duplex tray has been inserted.

6. DIP SWITCHES

6.1 DUPLEX CONTROL BOARD : DSW1

SW No.	Function
1	Adjustment Value
2	
3	Free Run
4	Adjustment Direction

SW1	SW2	Value
OFF	OFF	0 mm
ON	OFF	2 mm
OFF	ON	4 mm
ON	ON	6 mm

SW4

ON: [-] direction

OFF: [+] direction

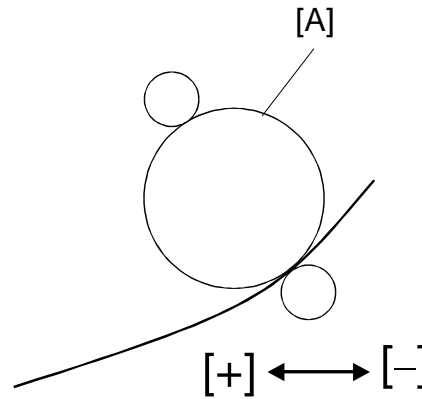

G694O505.wmf

Adjustment of the paper stop position at the duplex feed roller [A] (SW1,2,4)

If paper jams occur after changing the duplex turn sensor, because the sensor was not installed correctly, adjust the paper stop position at the duplex feed roller [A].

Free run (SW3)

The duplex transport and feed motor turn on with A4 sideways timing.

7. REPLACEMENT AND ADJUSTMENT

7.1 DUPLEX TRANSPORT UNIT REMOVAL

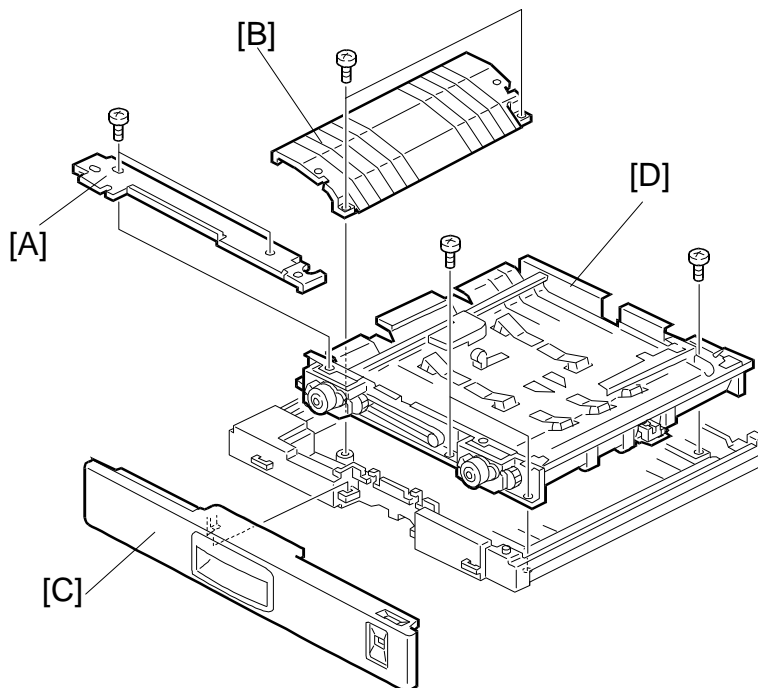

G694O503.wmf

1. Remove the inner cover [A] of the duplex tray (2 screws).
2. Remove the duplex control board cover [B] (2 screws).
3. Release the hook and remove the front cover [C].
4. Remove the duplex transport unit [D] (4 screws, 4 connectors).

7.2 DUPLEX TRANSPORT AND FEED MOTOR REPLACEMENT

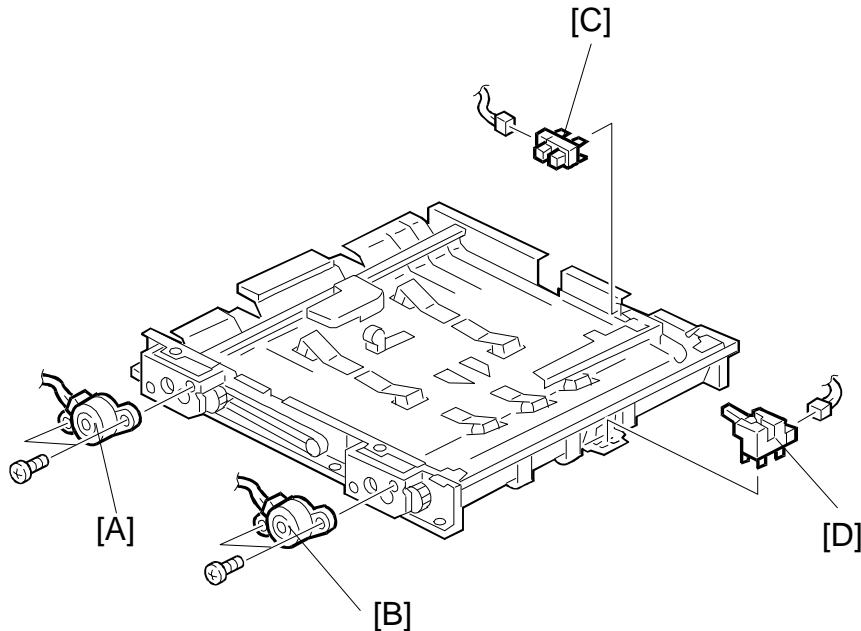

G694O504.wmf

1. Remove the transport unit.
2. Replace the duplex transport motor [A] (2 screws, 1 connector).
Replace the duplex feed motor [B] (2 screws, 1 connector).

7.3 DUPLEX TURN AND DUPLEX EXIT SENSORS

1. Remove the duplex transport unit.
2. Replace the duplex turn sensor [C] (1 connector).
Replace the duplex exit sensor [D] (1 connector).

7.4 DUPLEX JUNCTION GATE SOLENOID AND DUPLEX ENTRANCE SENSOR REPLACEMENT

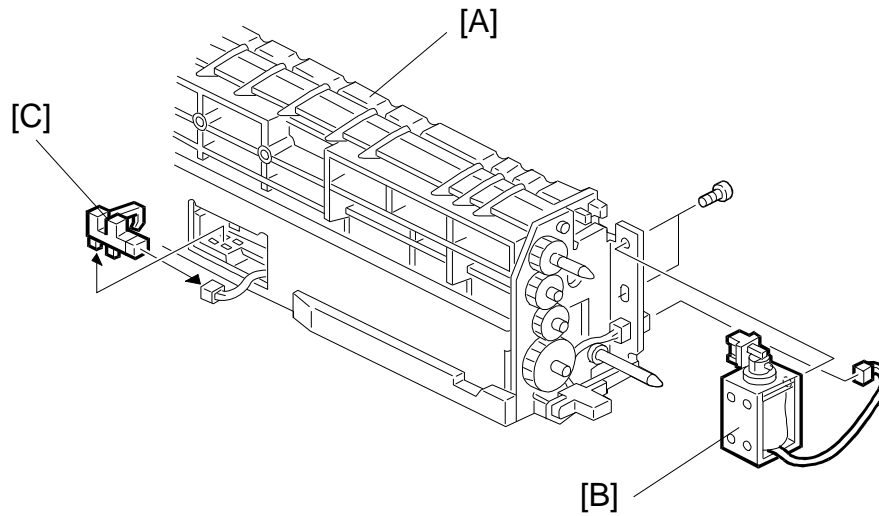

G694O012.wmf

1. Remove the inverter unit [A] (1 screw).
2. Replace the junction gate solenoid [B] (2 screws, 1 connector)
Replace the duplex entrance sensor [C] (1 connector).

DUPLEX UNIT INSTALLATION

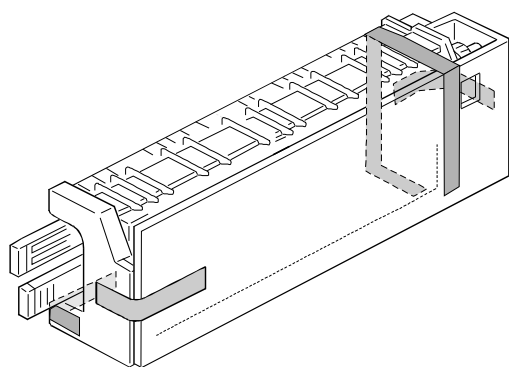

G694I500.wmf

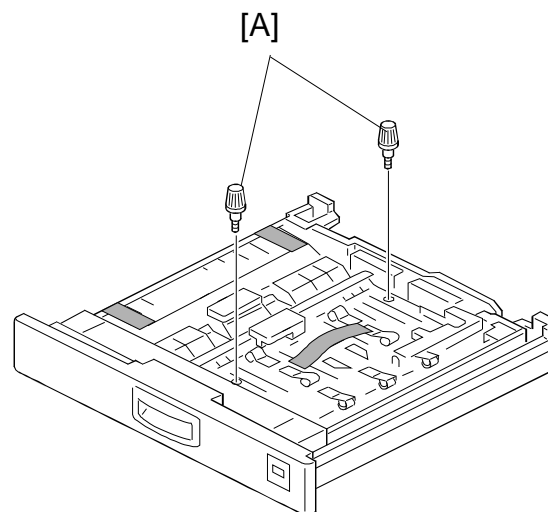

G694I508.wmf

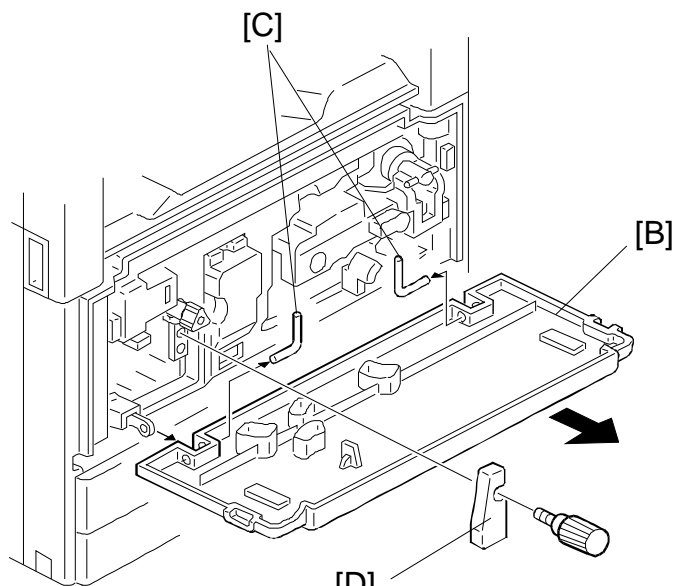

G694I502.wmf

Installation

⚠ CAUTION

Unplug the copier power cord before starting the following procedure.

1. Unpack the inverter unit and duplex unit and remove the tapes (7 tapes) and two knob screws [A].
2. Open the front cover [B].
3. Slide the two hinges [C] inward and remove them as shown in the illustration. Then, remove the front cover.
4. Remove the inverter unit cover [D] (1 screw).

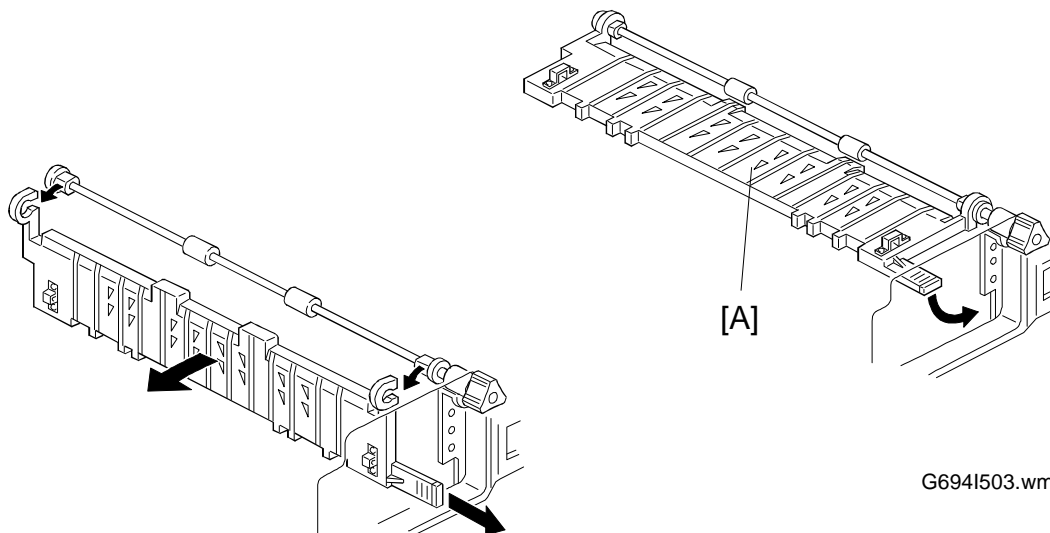

G694I503.wmf

G694I504.wmf

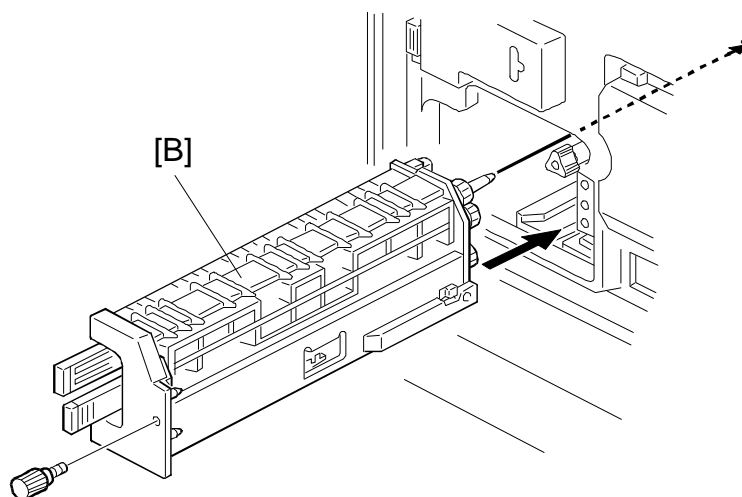

G694I505.wmf

5. Swing the lower transport guide plate [A] down as shown in the illustration.
6. Remove the lower transport guide plate and pull it out as shown in the illustration.
7. Push the inverter unit [B] in until the pin is completely inserted in the pin hole.
8. Secure the inverter unit with the screw which was removed in step 4.

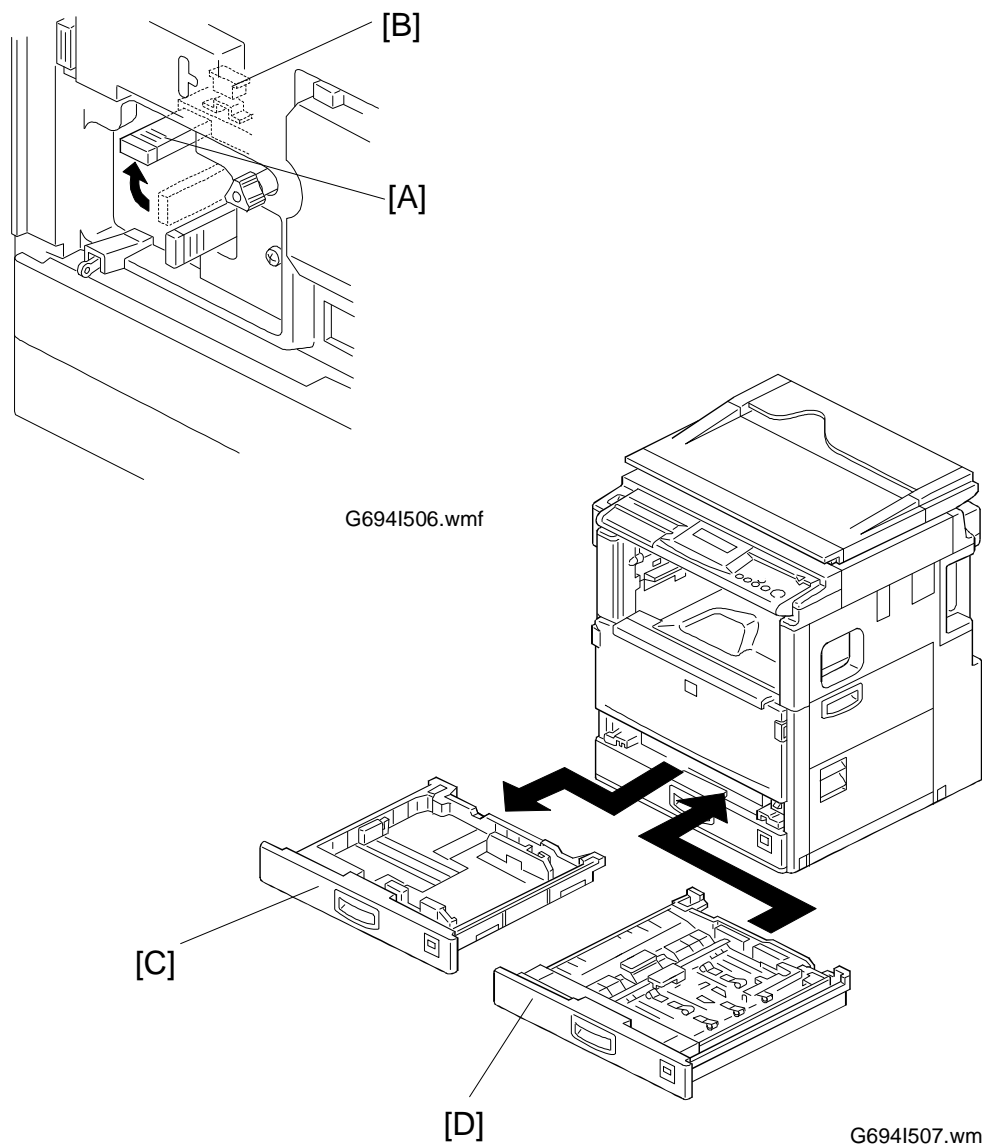

Installation

9. Swing the upper inverter guide plate [A] up as shown in the illustration and secure it with the magnets [B] at front and rear.
10. Reinstall the front cover.
11. Pull out the 1st paper tray [C].
12. Push the duplex unit [D] into the place where the 1st paper tray was.
13. Turn the ac and main switches on and check if the duplex unit works properly.

Duplex (G694)

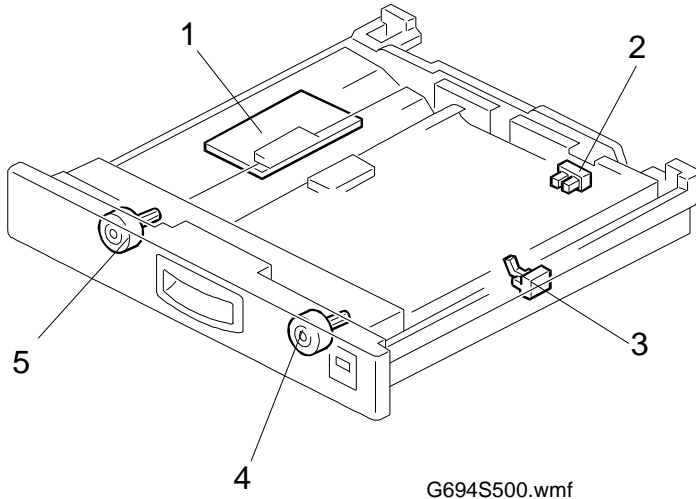

G694S500.wmf

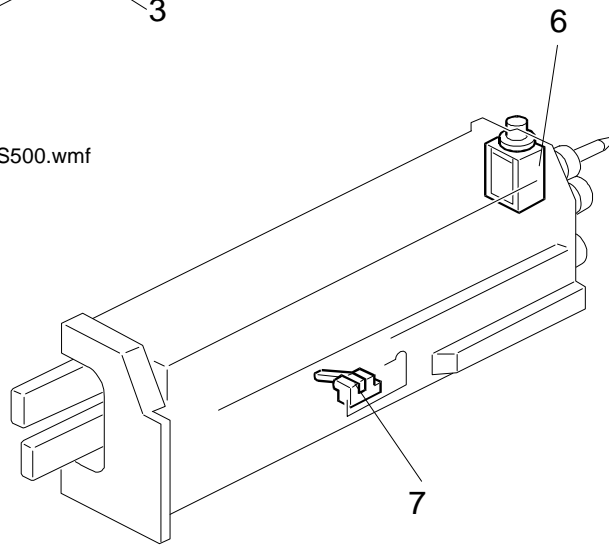

G694S501.wmf

Duplex (G694)

Symbol	Index No.	Description	P to P (1/2)
Motors			
M1	5	Duplex Transport	B9
M2	4	Duplex Feed	C9
Sensors			
S1	7	Duplex Entrance	B11
S2	2	Duplex Turn	C12
S3	3	Duplex Exit	C12
Solenoid			
SOL1	6	Duplex Junction Gate Control	B11
PCBs			
PCB1	1	Duplex Control	C11